

GEDORE

TOOLS FOR LIFE



04/2020

Wheel hub puller for commercial vehicles

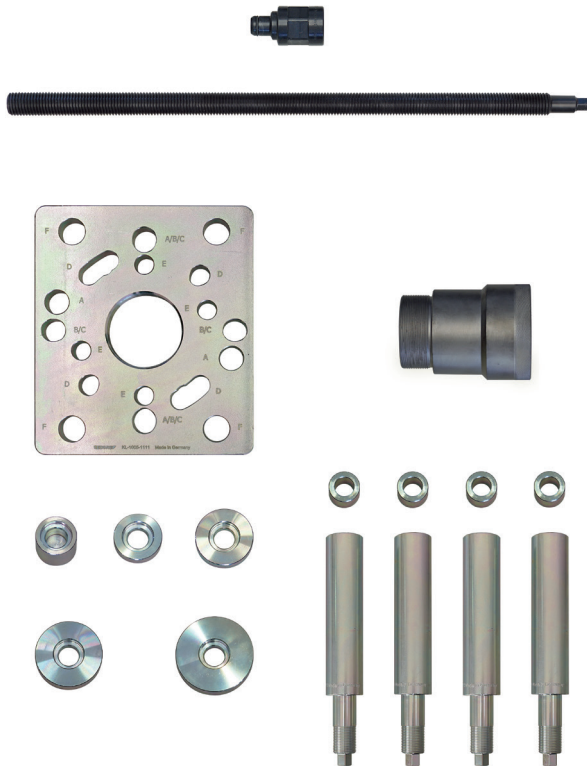

KL-1005-110

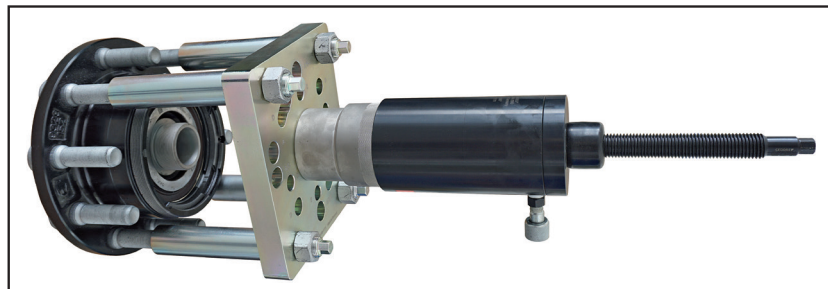

EN

www.gedore-automotive.com

GEDORE Automotive GmbH

Breslauer Straße 41
78166 - Donaueschingen
Postfach 1329
78154 Donaueschingen - GERMANY

T +49 (0) 771 / 8 32 23-0
F +49 (0) 771 / 8 32 23-90
info.gam@gedore.com
www.gedore-automotive.com

GEDORE TOOLS, INC.

Only for USA, Canada & Mexico
Sólo para EE.UU., Canadá y México
Seulement pour les USA, le Canada et le Mexique
7187 Bryhawke Circle, Suite 700
North Charleston, SC 29418, USA
Phone +1-843 / 225 50 15
Fax +1-843 / 225 50 20
info@gedoretools.com

GEDORE WELTWEIT / GEDORE WORLDWIDE

Weltweite GEDORE Servicestellen / Niederlassungen finden Sie im Internet unter: www.gedore.com
Worldwide GEDORE service centers / offices are listed on the Internet at: www.gedore.com



English

EN

2 - 11

Imprint

Im Zuge der Verbesserung und Anpassung an den Stand der Technik behalten wir uns Änderungen im Hinblick auf Aussehen, Abmessungen, Gewichte und Eigenschaften sowie Leistungen vor.

Damit ist kein Anspruch auf Korrektur oder Nachlieferung bereits gelieferter Produkte verbunden. Streichungen können jederzeit vorgenommen werden, ohne dass ein rechtlicher Anspruch entsteht.

Alle Hinweise zur Benutzung und Sicherheit sind unverbindlich. Sie ersetzen keinesfalls irgendwelche Gesetzlichen oder Berufsgenossenschaftlichen Vorschriften.

Für Druckfehler übernehmen wir keine Haftung.

Ein Nachdruck, auch auszugsweise, bedarf der vorherigen schriftlichen Zustimmung durch **GEDORE Automotive GmbH**.

Alle Rechte weltweit vorbehalten.

Wir verweisen auf unsere Allgemeinen Geschäftsbedingungen, ersichtlich im Impressum unter www.gedore-automotive.com.

© Copyright by **GEDORE Automotive GmbH Donaueschingen (GERMANY)**

Impressum/Legal Notice

As part of our commitment to continuous product improvement and adaptation to state-of-the art technology, we reserve the right to make modifications to our products with regard to design, dimension, weight, features and performances at any time and without prior notice.

Thus, the right to adjustments or replacement deliveries of goods already delivered is excluded. Cuts and cancellations can be made by us at any time without notice and no legal claims against us may arise or be derived from this.

All indications regarding use and safety are given for information only and without any commitment. In no case do they substitute for legal provisions or the regulations of the Employer's Liability Insurance Association.

Errors and omissions excepted.

Any reproduction, also in extracts, is subject to the prior written consent of **GEDORE Automotive GmbH**.

All rights reserved.

We refer to our General Terms and Conditions of Sale under 'Imprint' at www.gedore-automotive.com.

© Copyright by **GEDORE Automotive GmbH Donaueschingen (GERMANY)**

Impressum/Mentions légales

En raison des améliorations continues que nous apportons à nos produits et pour assurer leur adaptation constante à l'évolution des techniques, nous nous réservons le droit de procéder à des modifications de nos produits quant à l'apparence, aux dimensions, aux poids, aux caractéristiques et aux performances à tout moment sans préavis et sans obligation de modifier ou de remplacer des produits précédemment livrés.

Des suppressions peuvent être effectuées à tout moment et sans préavis sans qu'elles puissent donner lieu à réclamation.

Toutes les instructions d'utilisation et conseils de sécurité sont donnés sans engagement de notre part. Ils ne se substituent en aucun cas aux réglementations légales en vige eur ou à celles émises par les associations professionnelles.

Le plus grand soin possible a été apporté à la rédaction de ce document. Toutefois, nous n'assumons aucune responsabilité pour des erreurs, omissions ou défauts d'impression éventuels.

Une reproduction, même en partie, ne peut être effectuée qu'après autorisation écrite préalable de **GEDORE Automotive GmbH**.

Tous droits réservés.

Vous trouverez nos conditions générales de vente, sous Impressum/Mentions légales sur www.gedore-automotive.com.

© Copyright by **GEDORE Automotive GmbH Donaueschingen (GERMANY)**

Contents

1. Basic safety instructions	4
1.1 Target group	4
1.2 Intended use	4
1.3 Misuse/abuse	4
1.4 Personal protective equipment	4
1.5 Basic warnings	5
1.6 Handling	5
1.7 Work environment	5
1.8 Emissions	5
2. Product description	6
2.1 KL-1005-110 - wheel hub puller for commercial vehicles	6
2.2 Scope of delivery/spare parts	6
2.3 Specifications	6
3. Preparations	7
3.1 Checking the scope of delivery	7
3.2 Preparing the tool	7
3.3 Preparing the vehicle	7
4. Typical application	8
4.1 Using the threaded holes on the hub to pull off the wheel hub/bearing unit.	8
4.2 Using the wheel studs of low-loaders to pull off the wheel hub/bearing unit.....	10
5. Care and storage	11
6. Maintenance and repair by the GEDORE Automotive Service Center	11
7. Environmentally friendly disposal	11

1. Basic safety instructions

WARNING

Read and understand the operating instructions before you start using the wheel hub puller. Misuse can result in **severe or fatal injuries**.

The operating instructions are a part of the wheel hub puller. Keep these operating instructions at a safe place for future reference, and always pass them on to subsequent users of the wheel hub puller.

1.1 Target group

These operating instructions are intended for skilled personnel in motor vehicle workshops.

Never allow unauthorised persons or minors to use the wheel hub puller.

The purchaser of the wheel hub puller **must** ensure that the user has read and understood the operating instructions completely before he or she uses the wheel hub puller.

The operating instructions **must** be available at all times to the user of the wheel hub puller.

1.2 Intended use

The wheel hub puller is **used only** to pull off wheel hub/bearing units with removable hub caps.

The wheel hub puller may **only be used** by skilled personnel in motor vehicle workshops.

The wheel hub puller **may only be used** in the way that is described in the operating instructions.

- Any other use can result in **severe or fatal injuries**.



1.3 Misuse/abuse

Never subject the wheel hub puller to technical modifications or additions or conversions that could have even the slightest effect on safety.

- **Never** use the wheel hub puller to press in or out bushes, bolts or the like.
- **Always** read and observe **all** warnings, safety instructions and other instructions for the operation and maintenance of the wheel hub puller!
- The wheel hub puller **may only be used** in the way that is described in **Chapter 1.2 - Intended use**. • Any other use can result in **severe or fatal injuries**.



1.4 Personal protective equipment

Always wear your personal protective equipment when you use the wheel hub puller. The wheel hub puller can bring about mechanical hazards such as crushing, cutting and shock injuries.

-  **EYE PROTECTORS** (see OSHA 29 CFR 1910.133 and ANSI Z87) must be worn when using the wheel hub puller, to protect against flying objects.
 - Particles can be thrown up when working with the wheel hub puller, and cause severe injuries to your eyes.
-  **PROTECTIVE GLOVES** must be worn when using the wheel hub puller.
 - Working with the wheel hub puller can cause skin abrasions and crushing.
-  **SAFETY SHOES** with anti-slip sole and steel toe cap (see OSHA 29 CFR 1910.136 and ANSI Z41) **must** be worn when using the wheel hub puller.
 - Dropping parts can cause injuries to feet and toes.

1.5 Basic warnings

For better differentiation, warnings in these operating instructions are classified as follows:

Warning sign	Signal word	Meaning
	WARNING	Indicates a hazardous situation which, if not avoided, can cause severe or even fatal injuries .
	CAUTION	Indicates a hazardous situation which, if not avoided, can cause medium or light injuries .
	ATTENTION	Indicates a situation which, if not avoided, can cause damage to the tool or its functions or an object in its vicinity.
	Note / Tip	Indicates important information and useful tips for use.

WARNING

Using unsuitable driving components can cause **severe or fatal injuries**.

- The wheel hub puller may only be actuated with suitable drive components and/or hydraulic cylinder/pump combinations which ensure safe operation!

During the removal of compact wheel hub/bearing units and of wheel hubs, there is a risk of the wheel hub puller breaking and parts flying about. This can result in **severe or fatal injuries**.

- Do not exceed the **maximum loading capacity of 28t** of the wheel hub puller!
- Ensure that work on vehicles is carried out always in compliance with the instructions and safety regulations of the vehicle manufacturer.
- Wear personal protective equipment (safety goggles, protective gloves, safety shoes).
- Use **only genuine GEDORE Automotive** spare parts and accessories.
- Never stand in the axial extension of the wheel hub puller.

A dropping wheel hub puller can cause severe injuries.

- Secure the wheel hub puller against falling down, for example using the safety retaining belt - **KL-0040-2890** (*accessories/ see catalogue*).

CAUTION

Risk of damaging wheel hub puller and vehicle.

- Lubricate spindles and threads on the wheel hub puller **only** with molybdenum disulphide paste, e.g. **KL-0014-0030** (*accessories/ see catalogue*).
- Only the data and instructions issued by the vehicle manufacturer apply for any work on the vehicle.

1.6 Handling

CAUTION

Observe the following safety precautions to avoid injuries and material damage as a result of misuse and unsafe handling of the wheel hub puller. **Misuse can result in severe or fatal injuries**.

- **Before each use**, ensure that the wheel hub puller is in a technically perfect condition. Damaged or worn parts **must** be replaced before use.
- Use **only genuine GEDORE Automotive** spare parts and accessories for the wheel hub puller!

1.7 Work environment

Safe work with the wheel hub puller is only possible when the working environment is safe.

- The workplace **must** be clean and tidy.
- The workplace **must** be sufficiently large and protected.
- The workplace **must** be on a solid non-skidding floor.

1.8 Emissions

Molybdenum disulphide paste and hydraulic oil can drip and/or leak when using the wheel hub puller and thus pose a hazard to the environment.

- Collect dripping and escaping hazardous substances immediately in a suitable container and/or remove it with a cleaning cloth or binding agent, and dispose of in an environmentally friendly manner.

2. Product description

If you have any questions, please contact:
GEDORE Automotive GmbH
Breslauerstr. 41 // 78166 Donaueschingen
Phone: +49 771 8 32 23 71 // E-mail: info.gam@gedore.com

2.1 KL-1005-110 - wheel hub puller for commercial vehicles

Universally suitable for commercial vehicle wheel hub/bearing units with removable hub cover, for axle systems with a hole circle Ø on the hub of 10x120, 10x122, 10x143, 10x165, 10x168, 12x144, 12x145, 12x164, 12x168, 14x138, 14x144 and for low-loaders on the wheel hub of 10x225. Installed for example for tractors, semi-trailers and low-loaders, such as Mercedes Actros, Antos, Atego, Axor, Eonic; Neoplan; MAN F2000, L2000, M2000L, M2000M, TGA, TGM, TGS, TGL, TGX; Renault Magnum, Midlum, Midlum Premium, Midliner CE, M, ME, MS, S, SE; DAF LF45, LF55, LF (Euro 6); Iveco Eurocargo; Volvo FL; VDL Bova bus, city bus; Gigant Protec DNOKH2, Krone; Kögel KTA; low-loader: BPW, Gigant, SAF; SAF Holland axle series SKRLB 9019 W, SKRB 10022; GFA rigid axles; trailer/semitrailers Kögel, Schmitz Cargobull, Wielton, ZF etc.)

The wheel hub puller permits wheel hub/bearing units with removable hub caps to be pulled off quickly and professionally. After the hub cap has been removed, the unit is removed via the threaded holes on the hub or, in the case of low-loaders, via the wheel bolts on the wheel hub. Support is provided centrally via the axle tube, using the different thrust discs. The special adapter plate offers universal adaptation to a large number of bolt hole circles that are available on the market.

The 28t hydraulic cylinder, which is available as an accessory, allows even heavily jammed wheel hubs to be removed quickly and easily.

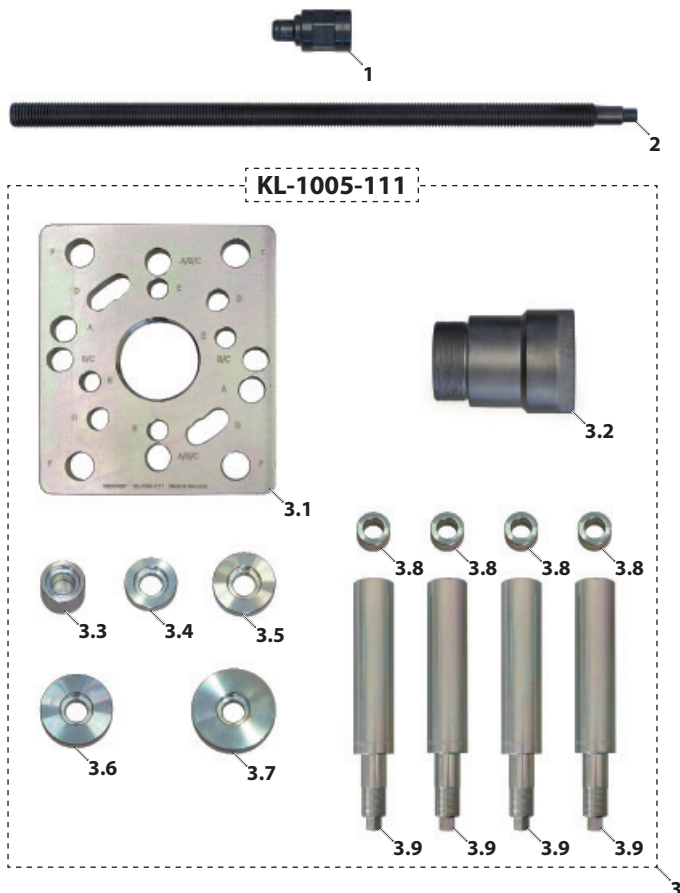

2.2 Scope of delivery/spare parts:

KL-1005-110 - Wheel hub puller compact bearing			
Item	Part no.	Description	Quantity
1	KL-0040-2812-5	Thrust nut M24, Ø 20.5 mm	1
2	KL-0040-2812-1	Thrust spindle M24 x 590 mm	1
3	KL-1005-111	Base tool kit	1
3.1	KL-1005-1111	Adapter plate	1
3.2	KL-1005-1112	Extension 2 ¾"	1
3.3	KL-1005-1115	Thrust disc short	1
3.4	KL-1005-1116	Thrust disc Ø 48 mm	1
3.5	KL-1005-1117	Thrust disc Ø 58 mm	1
3.6	KL-1005-1118	Thrust disc Ø 68 mm	1
3.7	KL-1005-1119	Thrust disc Ø 78 mm	1
3.8	KL-1005-1114	Intermediate sleeve	4
3.9	KL-1005-1113	Adapter spindle low-loader M22x1.5	4

KL-1005-11 - Wheel hub puller commercial vehicle

Same scope of delivery as **KL-1005-110**, but additionally with the 28t hydraulic cylinder - **KL-0040-2800**.

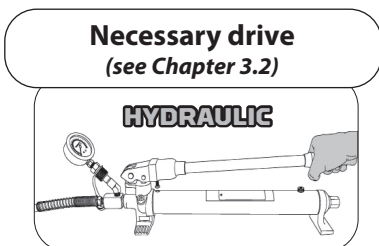

2.3 Specifications

Max. load: 28t
Hub hole circle: 10x120, 10x122, 10x143, 10x165, 10x168, 12x144, 12x145, 12x164, 12x168, 14x138, 14x144
Wheel hub hole circle for low-loaders: 10x225

Fig. 1: Necessary drive:

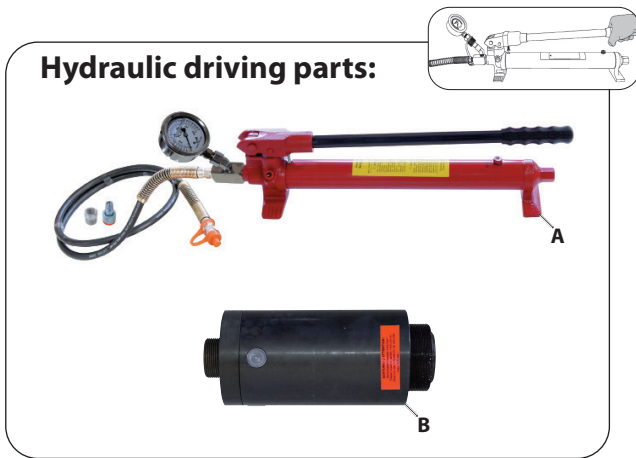

Fig. 2: Preparing the hydraulic cylinder "B".

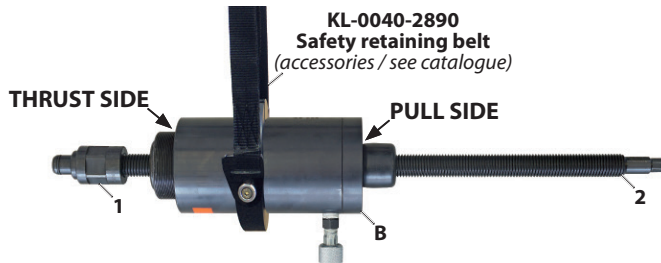

Fig. 3: Preparing the vehicle.

A Preparing wheel hub/bearing unit.

Variant A



B Preparing wheel hub/bearing unit for low-loaders.

Variant B

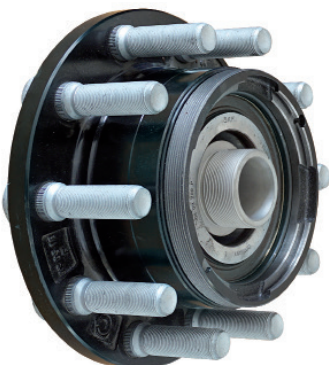

3. Preparations

Prior to using the wheel hub puller for the first time, check and ensure that all parts of the scope of delivery are available. Follow the instructions below.

3.1 Checking the scope of delivery

3.2 Necessary drive

⚠ WARNING

Using unsuitable driving components can cause **severe or fatal injuries**.

- The wheel hub puller **may only** be actuated with suitable drive components and/or hydraulic cylinder/pump combinations which ensure safe operation!

Hydraulic driving parts: (Fig. 1)

Item	Part no.	Description
A	KL-0040-35 M28	Hydraulic pump with 28t manometer
B	KL-0040-2800	Hydraulic cylinder 28t

3.3 Preparing the tool.

- 1) Screw the thrust nut "1" completely onto the thrust spindle "2". Next, screw both together into the hydraulic cylinder "B" as shown in Fig. 2.

Note:

There is a thrust and a pull side on the hydraulic cylinder "B"!

The safety retaining belt - KL-0040-2890 (accessories/see catalogue) permits the wheel hub puller to be secured to the vehicle, thus preventing it from dropping.

2. Measure the inner diameter of the wheel hub/bearing unit to determine the suitable thrust disc "3.3, 3.4, 3.5, 3.6 or 3.7".
Next, select the suitable thrust disc "3.3 ... 3.7" such that it is smaller than the inner diameter of the wheel hub/bearing unit, but rests safely and over its entire surface on the axle tube.

3.4 Preparing the vehicle

Depending on the wheel hub/bearing unit, loosen or remove all necessary parts as specified by the manufacturer (for example, unscrew wheels, remove hub caps, loosen and remove central nut on wheel bearing). (see variants A and/ or B)

➔ Variant A

- 1) Preparing the wheel hub/bearing unit. (Fig. 3 A)
- 2) Continue with **Chapter 4.1** Using the threaded holes on the hub to pull off the wheel hub/bearing unit.

➔ Variant B

- 1) Prepare the wheel hub/bearing unit **for low-loaders**. (Fig. 3 B)
- 2) Continue with **Chapter 4.2** Using the wheel studs of low-loaders to pull off the wheel hub/bearing unit.

Fig. 4: Hole pattern overview adapter plate "3.1"

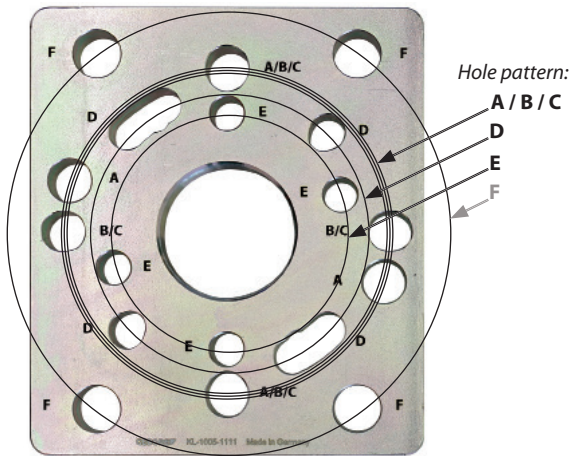

Fig. 5: Install the adapter plate "3.1" on the wheel hub/bearing unit such that it matches the **hole pattern**.

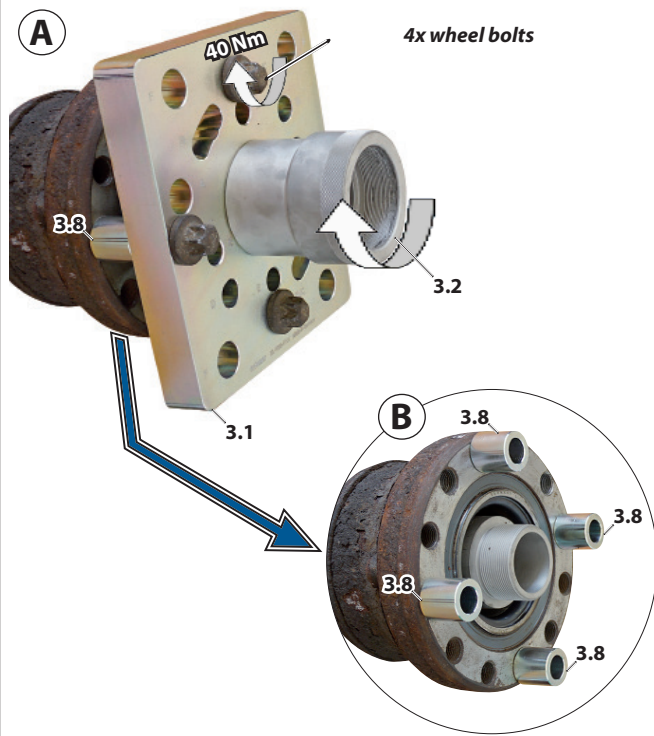
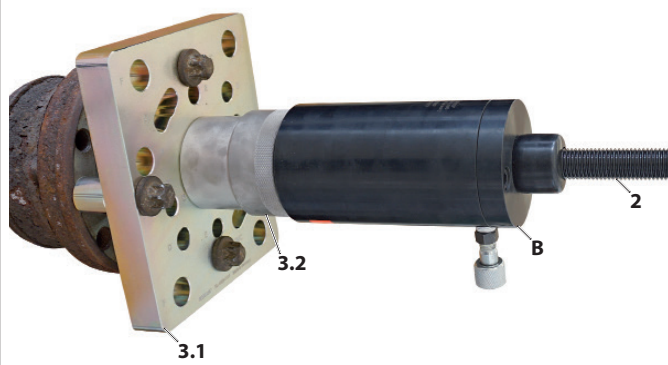

Fig. 6: Screw the prepared hydraulic cylinder "B" into the extension "3.2".



4. Typical application

4.1 Using the threaded holes on the hub to pull off the wheel hub/bearing unit.

This typical application describes the removal of a wheel hub/bearing unit with removable hub cap. After the necessary parts have been removed, the threaded holes on the hub are used for pulling off. Support is provided centrally via the axle tube, using the matching thrust piece.

- 1) Determine the hole circle on the wheel hub/bearing unit. Next, use the hole circle overview below and select the appropriate **hole pattern A ... E** on adapter plate "3.1".

Hole circle overview (see Fig. 4)	
Adapter plate "3.1"	Hole circle
Hole pattern A	10x165 / 10x168
Hole pattern B	12x168
Hole pattern C	12x164
Hole pattern D	10x143 / 12x144 12x145 / 14x138 / 14x144
Hole pattern E	10x120 / 10x122
Hole pattern F	10x225

- 2) Prepare the vehicle wheel bolts so that the adapter plate "3.1" can securely be bolted to the wheel hub/bearing unit.

⚠ WARNING

During the removal of wheel hub/bearing units, there is a risk of the wheel hub puller breaking and parts flying about. This can result in **severe or fatal injuries**.

- The screw-in depth of the wheel bolts must be sufficient.
- Generally, **4 wheel bolts must always be used to screw the adapter plate "3.1" to the wheel hub/bearing unit.**
- The wheel bolts **must** be completely screwed into the wheel hub/bearing unit in diagonally opposite sequence.

- 3) Position the adapter plate "3.1", together with the intermediate sleeves "3.8" (Fig. 5 B) and the correct wheel bolts on the wheel hub/bearing unit such that it matches the **hole pattern**. Tighten with **40 Nm**. (Fig. 5 A)

- 4) Screw the extension "3.2" completely into the adapter plate "3.1". (Fig. 5 A)

- 5) Screw the prepared hydraulic cylinder "B" completely into the extension "3.2" on the adapter plate "3.1". (Fig. 6)

Fig. 7: Position the matching thrust disc "3.3 ... 3.7".

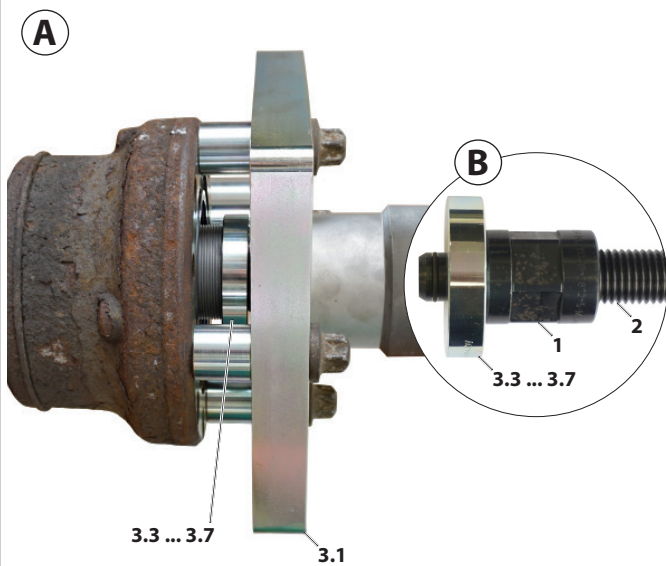

CAUTION

There is a risk of damaging axle tube and thrust discs "3.3 ... 3.7".

- Use the matching thrust disc "3.3 ... 3.7". It **must** be smaller than the inner diameter of the wheel hub/bearing unit, but rest safely and over its entire surface on the axle tube.!

- 6) Position the matching thrust disc "3.3 ... 3.7" in the correct position on the thrust nut "1". (Fig. 7 A+B)

⚠ WARNING

Using unsuitable driving components can cause **severe or fatal injuries**.

- The wheel hub puller **may only** be actuated with suitable drive components and/or hydraulic cylinder/pump combinations which ensure safe operation!

- 7) Connect the hydraulic pump "A" to hydraulic cylinder "B".

Fig. 8: Pull off the wheel hub/bearing unit.

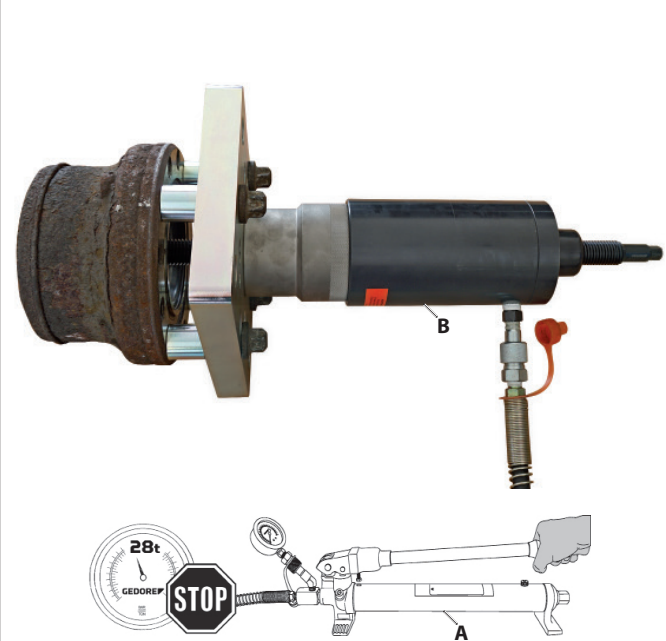

⚠ WARNING

During the removal of wheel hub/bearing units, there is a risk of the wheel hub puller breaking and parts flying about. This can result in **severe or fatal injuries**.

- Do not exceed the maximum loading capacity of **28t** of the wheel hub puller!
- Wear personal protective equipment (safety goggles, protective gloves, safety shoes).
- Never stand in the axial extension of the wheel hub puller.

There is a risk of **severe injuries** if the wheel hub puller and wheel hub/bearing assembly drop.

- Secure the wheel hub puller against dropping, for example using the safety retaining belt - **KL-0040-2890** (accessories/ see catalogue).
- Pull off the wheel hub/bearing unit only to the extent that it sits loosely on the axle tube.

- 8) Actuate the hydraulic pump "A" and **pull off** the wheel hub/bearing unit **only to the extent that it sits loosely** on the axle tube.

During the removal procedure, watch the required force on the pressure gauge of hydraulic pump "A"! (Fig. 8)



Note

The maximum stroke of the hydraulic cylinder "B" is **50 mm!**
As soon as a high pressure builds up at the hydraulic pump "A": Interrupt the pull-off process. Release pressure at hydraulic pump "A", screw in thrust spindle "2" until thrust disc "3.3 ... 3.7" is again in full contact with the axle tube. Continue the pull-off process.

- 9) Carry out further repair work on the vehicle in accordance with the manufacturer specifications.

Fig. 9: Use hole pattern F for low-loaders with 10x225 hole circle.

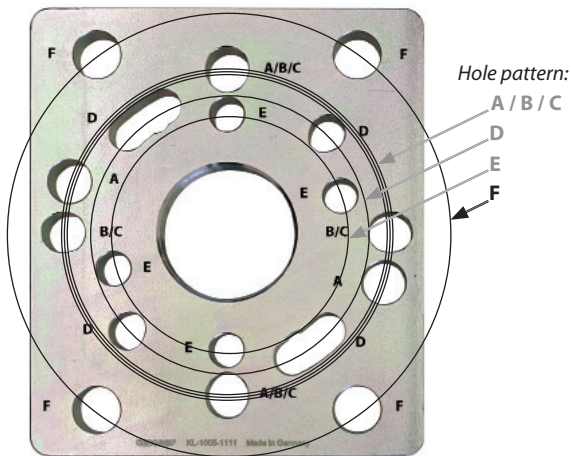

Fig. 10: Screw adapter spindles "3.9" on the wheel bolts.

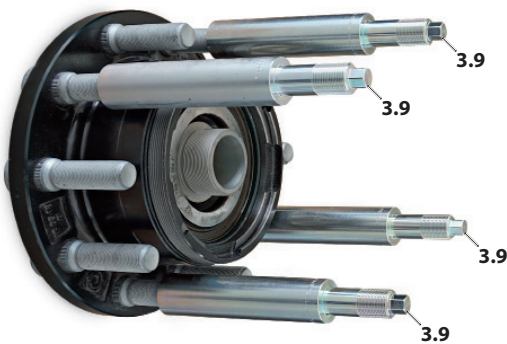

Fig. 11: Position the adapter plate "3.1" over hole pattern F.

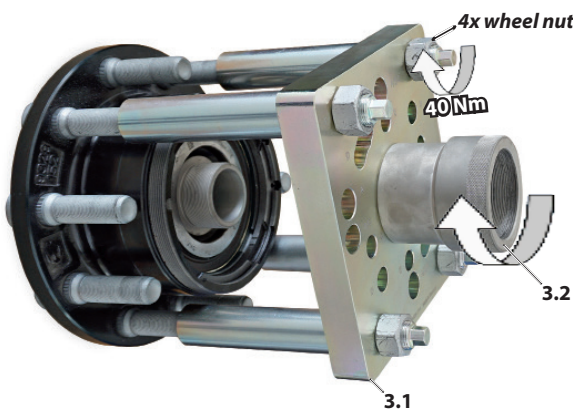
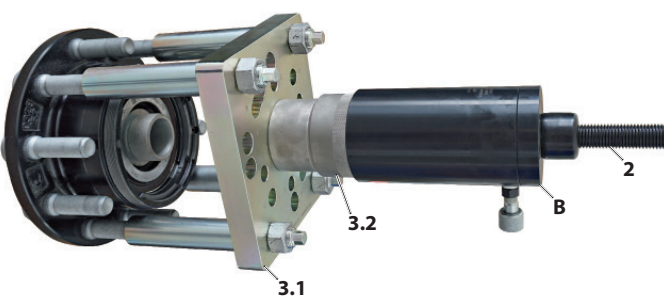

Fig. 12: Screw the prepared hydraulic cylinder "B" into the extension "3.2".



4.2 Using the wheel studs of low-loaders to pull off the wheel hub/bearing unit.

This typical application describes the removal of a wheel hub/bearing unit with removable hub cap on a low-loader. After the necessary parts have been removed, the wheel bolts on the hub are used for pulling off. Support is provided centrally via the axle tube, using the matching thrust piece.

- 1) For low-loaders with hole circle 10x225, use the matching hole pattern F on adapter plate "3.1". (see hole circle overview)

Hole circle overview (see Fig. 9)

Adapter plate "3.1"	Hole circle
Hole pattern A	10x165 / 10x168
Hole pattern B	12x168
Hole pattern C	12x164
Hole pattern D	10x143 / 12x144 12x145 / 14x138 / 14x144
Hole pattern E	10x120 / 10x122
Hole pattern F	10x225

- 2) Prepare the vehicle wheel bolts so that the adapter plate "3.1" can securely be bolted to the wheel hub/bearing unit via the adapter spindles "3.9".

⚠ WARNING

During the removal of wheel hub/bearing units, there is a risk of the wheel hub puller breaking and parts flying about. This can result in **severe or fatal injuries**.

- The adapter spindles "3.9" **must** be completely screwed onto the wheel bolts on the wheel hub/bearing unit in diagonally opposite sequence.
- Generally, all 4 adapter spindles "3.9" **must always** be used to screw the adapter plate "3.1" to the wheel hub/bearing unit.

- 3) Screw all 4 adapter spindles "3.9" in diagonally opposite sequence onto the wheel studs, as shown in Fig. 10.

Position the adapter plate "3.1" above **hole pattern F** on the adapter spindles "3.9", and secure it with the matching wheel nuts tightened with 40 Nm. (Fig. 11)

- 4) Screw the extension "3.2" completely into the adapter plate "3.1". (Fig. 11)

- 5) Screw the prepared hydraulic cylinder "B" completely into the extension "3.2" on the adapter plate "3.1". (Fig. 12)

Fig. 13: Position the matching thrust disc "3.3 ... 3.7".

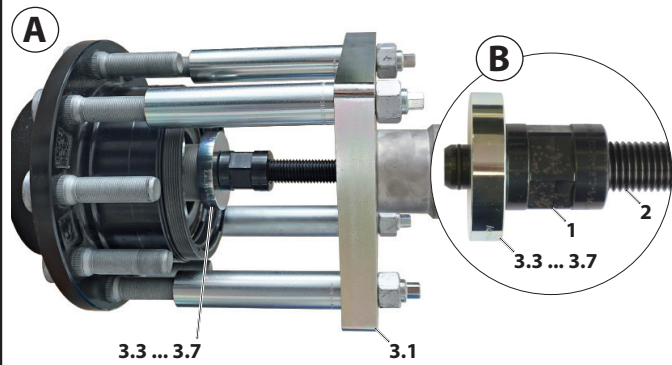
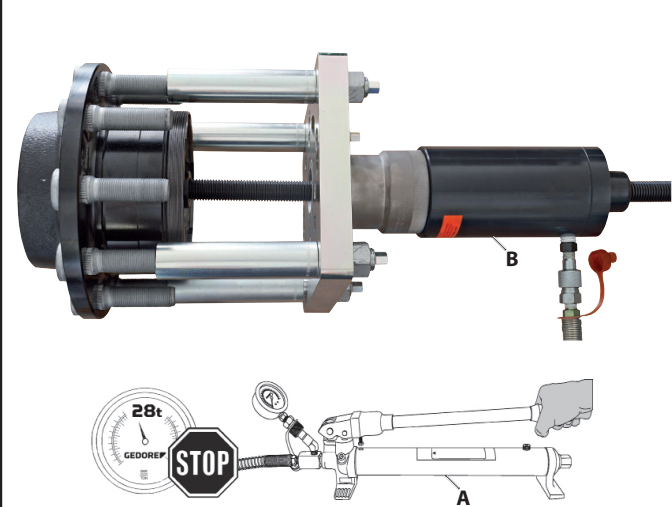

Fig. 14: Pull off the wheel hub/bearing unit.



Note

The maximum stroke of the hydraulic cylinder "B" is 50 mm!
As soon as a high pressure builds up at the hydraulic pump "A":
Interrupt the pull-off process. Release pressure at hydraulic pump "A", screw in thrust spindle "2" until thrust disc 3.3 ... 3.7" is again in full contact with the axle tube. Continue the pull-off process.

CAUTION

There is a risk of damaging axle tube and thrust discs "3.3 ... 3.7".

- Use a suitable thrust disc "3.3 ... 3.7". It **must** be smaller than the inner diameter of the wheel hub/bearing unit, but rest safely and over its entire surface on the axle tube.!

- 6) Position the matching thrust disc "3.3 ... 3.7" in the correct position on the thrust nut "1". (Fig. 13 A+B)

WARNING

Using unsuitable driving components can cause **severe or fatal injuries**.

- The wheel hub puller **may only** be actuated with suitable drive components and/or hydraulic cylinder/pump combinations which ensure safe operation!

- 7) Connect hydraulic pump "A" to hydraulic cylinder "B".

WARNING

During the removal of wheel hub/bearing units, there is a risk of the wheel hub puller breaking and parts flying about. This can result in **severe or fatal injuries**.

- Do not exceed the maximum loading capacity of **28t** of the wheel hub puller!
- Wear personal protective equipment (safety goggles, protective gloves, safety shoes).
- Never stand in the axial extension of the wheel hub puller.

There is a risk of **severe injuries** if the wheel hub puller and wheel hub/bearing assembly drop.

- Secure the wheel hub puller against dropping, for example using the safety retaining belt - KL-0040-2890 (accessories/ see catalogue).
- Pull off the wheel hub/bearing unit only to the extent that it sits loosely on the axle tube.

- 8) Actuate hydraulic pump "A" and pull off the wheel hub/bearing unit **only to the extent** that it sits **loosely** on the axle tube.

During the removal procedure, watch the required force on the pressure gauge of hydraulic pump "A"! (Fig. 14)

- 9) Carry out further repair work on the vehicle in accordance with the manufacturer specifications.

5. Care and storage

CAUTION: Benzene and chemical solvents can damage plastic parts.

After each use, clean all parts with a clean cloth only. To protect them against corrosion, lightly rub all metal parts after use with an anti-corrosion oil or wax that is suitable for tool care.

Store the special tool at a dry and clean location.

6. Maintenance and repair by the GEDORE Automotive Service Center

CAUTION: For safety reasons, ensure that a damaged special tool is no longer used. Only specifically trained personnel are allowed to carry out professional inspection and repair. Improper repair of the special tool can result in **medium or light injuries**.

Consequently, please contact GEDORE Automotive GmbH: **GEDORE Automotive GmbH**
Breslauerstr. 41 // 78166 Donaueschingen // Phone: +49 771 83223 -71 // E-mail: info.gam@gedore.com

7. Environmentally compliant disposal

Dispose of special tool and packaging material in accordance with the legal requirements in an environmentally friendly manner.

**GEDORE-Werkzeugfabrik
GmbH & Co. KG**

Remscheider Straße 149
42899 Remscheid
GERMANY

Vertrieb DEUTSCHLAND

T + 49 2191 596-0
F + 49 2191 596-230

Sales INTERNATIONAL

T +49 2191 596-910
F +49 2191 596-911
info@gedore.com
www.gedore.com

Only for USA, Canada & Mexico
Sólo para EE.UU., Canadá y México
Seulement pour les USA, le Canada
et le Mexique

GEDORE TOOLS, INC.

7187 Bryhawke Circle, Suite 700
North Charleston, SC 29418
USA
Phone +1-843 / 225 50 15
Fax +1-843 / 225 50 20
info@gedoretools.com

**GEDORE WELTWEIT
GEDORE WORLDWIDE
GEDORE DANS LE MONDE**

Weltweite GEDORE Servicestellen / Niederlassungen
finden Sie im Internet unter: www.gedore.com

Worldwide GEDORE service centers /
offices are listed on the Internet at: www.gedore.com

Points de service / branches GEDORE dans le monde
peut être trouvé sur Internet à: www.gedore.com