

# ABL 3800 LED



LED



**D14324** : 12/24V left

**D14325** : 12/24V right

The ABL 3800 LED combination drive light is an ECE approved full LED product designed for on-road and off-road vehicles. It combines 5 functions: high/low beam, pilot light, turn signal and repeater.

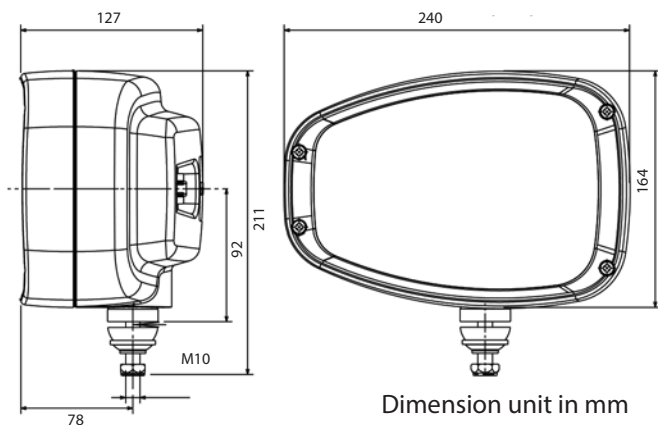

**D14352**

Built-in DT 6 ways

|                 |   |
|-----------------|---|
| Bulb            | Modules 100% LED  |
| Lifetime        | 20 000 hours  |
| Consumption     | High beam: 22W<br>Low beam: 32W                           |
| Voltage         | 12-24V  |
| EMC             | ISO 13 766<br>ISO 14 982<br>ISO 12 895<br>CISPR25 Class 3 |
| Water tightness | IP69K   |
| Operating temp  | -40°C to +85°C  |
| Lens            | Hardened glass  |

VIGNAL SYSTEMS  
12, rue Eugène Hénaff - BP 594  
F-69637 Vénissieux Cedex  
Tel: +33 (0)4 72 90 29 29  
Email: info@vignal-systems.com  
Site Web: www.vignal-systems.com

